

**Part Number: PT413-1C160**

**Kit Contents**

Item #	Quantity Req'd.	Description
1	1	RH Fog Light
2	1	LH Fog Light
3	1	RH Fog Light Adapter Bracket
4	1	LH Fog Light Adapter Bracket

**Hardware Bag Contents**

Item #	Quantity Req'd.	Description
1	1	Switch
2	1	Switch Harness
3	5	Wire Tie
4	3	Foam Pad
5	1	Relay
6	3	Scotchlok™
7	2	Adapter Harness
8	6	Screw, M4.8x13mm Hex-Head

**Additional Items Required For Installation**

Item #	Quantity Req'd.	Description
1		
2		
3		

**Conflicts**

None
------

**General Applicability**

All C-HR models
-----------------

**Recommended Sequence of Application**

Item #	Accessory
1	Fog Light Kit
2	Door Sill Protector
3	

\*Mandatory







**Recommended Tools**

<b>Personal &amp; Vehicle Protection</b>	Notes
Blankets	
<b>Special Tools</b>	Notes
Nylon Panel Removal Tool	
Hella Photometric Beam Setter (or equivalent)	DIO Only
<b>Installation Tools</b>	Notes
Ratchet	
Socket	8mm & 10mm Deep
Extension	8"
Diagonal Cutters	
Pliers	
Screwdriver	#2 Phillips & Short #2 Phillips & Small Flat-Blade
<b>Special Chemicals</b>	Notes
None	

**Vehicle Service Parts** (may be required for reassembly)

Item #	Quantity Req'd.	Description
1		
2		
3		

**Legend**

	<b>STOP:</b> Damage to the vehicle may occur. Do not proceed until process has been complied with.
	<b>OPERATOR SAFETY:</b> Use caution to avoid risk of injury.
	<b>CAUTION:</b> A process that must be carefully observed in order to reduce the risk of damage to the accessory/vehicle and to ensure a quality installation.
	<b>TOOLS &amp; EQUIPMENT:</b> Used in Figures calls out the specific tools and equipment recommended for this process.
	<b>REVISION MARK:</b> This mark highlights a change in installation with respect to previous issue.
	<b>SAFETY TORQUE:</b> This mark indicates that torque is related to safety.

Care must be taken when installing this accessory to ensure damage does not occur to the vehicle. The installation of this accessory should follow approved guidelines to ensure a quality installation.

These guidelines can be found in the "Accessory Installation Practices" document.

This document covers such items as:-

- Vehicle Protection (use of covers and blankets, cleaning chemicals, etc.).
- Safety (eye protection, rechecking torque procedure, etc.).
- Vehicle Disassembly/Reassembly (panel removal, part storage, etc.).
- Electrical Component Disassembly/Reassembly (battery disconnection, connector removal, etc.).

Please see your Toyota dealer for a copy of this document.

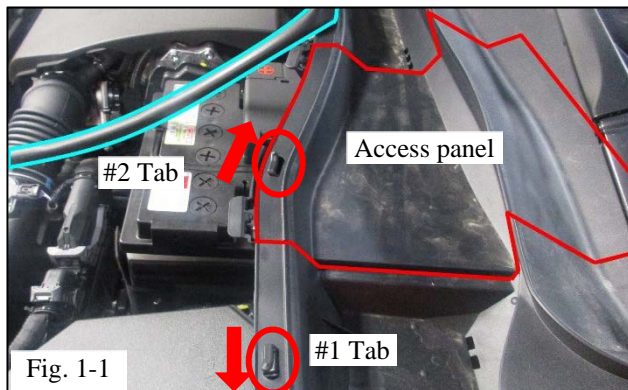

### 1. Prepare for the Installation.

- STOP** (a) The engine components and coolant may be hot.
- (b) Check the kit for contents and any damage.
- (c) Protect the fender.
- (d) Locate the hood weather-strip on the cowl trim (outlined in blue, Fig. 1-1).
- (e) Pull the weather-strip outboard and lift to remove it from Tab #1 (Fig. 1-1).
- (f) Push the weather-strip inboard and lift to remove it from Tab #2 (Fig. 1-1).
- (g) Lay the weather-strip away from the cowl (Fig. 1-1).

**⚠ NOTE:** Tab #1 and Tab #2 point in opposite directions. Take care not to damage the weather-strip during removal.

- (h) Disengage the Access Panel front clips (x2), then lift the panel up and away from the windshield edge to disengage the rear clips. Set the panel aside.

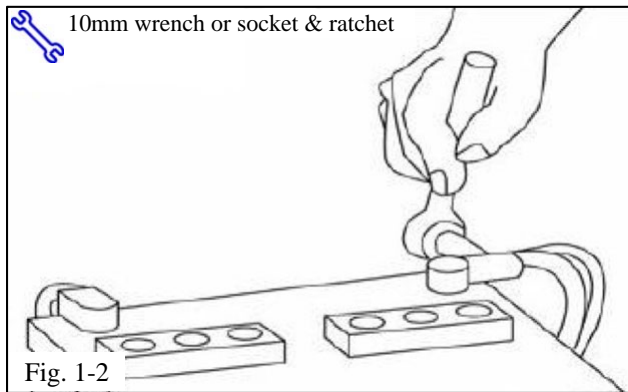

- ⚠ (i) Remove the battery cable from the negative terminal (Fig. 1-2).

⚠ **CAUTION:** Do not touch the positive terminal with any tool during removal.

## 2. Disassemble the Exterior.

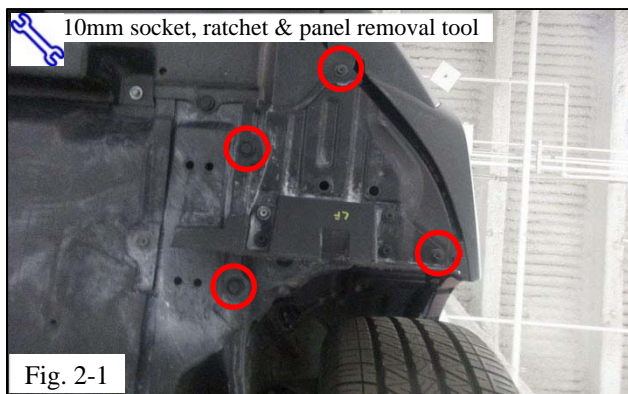

- (a) Remove the two (2) hex-head bolts and the (2) pop up fasteners (Fig. 2-1). Repeat the process on the other side.
- (b) Gently pull the fender under liner towards the back of the vehicle to allow access to the interior vehicle fog light area.

## 3. Mount the Fog Light to the Adapter.



- (a) Remove the three (3) self-tapping screws securing the cover on both sides of the vehicle and remove the cover on both sides (Fig. 3-1). Retain the screws for reuse.

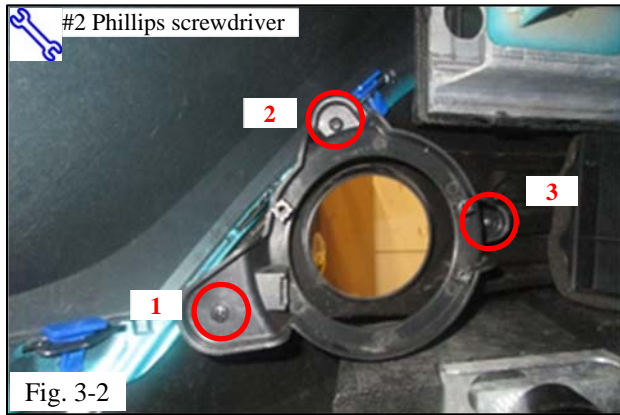

(b) Align the fog light adapter holes to the holes in the bumper cover, shown with screws secured (Fig. 3-2).

(c) Secure each light adapter bracket with the (3) screws removed in Step 3(a) in the sequence (Fig. 3-2) Make sure that all holes are aligned while securing the screws.

(1) If needed, after installing Screw #1, apply tape above Screw #2 to secure the adapter to the front bumper.

(2) If tape was applied, remove the tape after the adapter is fully secured with the screws.

(d) Repeat for the other side of the vehicle.

**⚠ NOTE:** Do not reuse the fasteners removed in Step 3(a).

**+ CAUTION:** Use wrist and arm protection while installing the Fog Lights to prevent injury.

#### 4. Install the Fog Lights

**⚠ NOTE:** The fog lights are marked with an “R” or “L” symbol indicating the right or left side of the vehicle holes (red circles, Fig. 4-1 [Right hand shown in Fig. 4-1]).

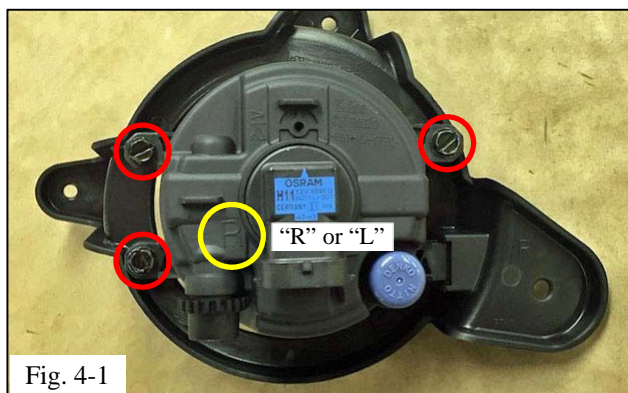

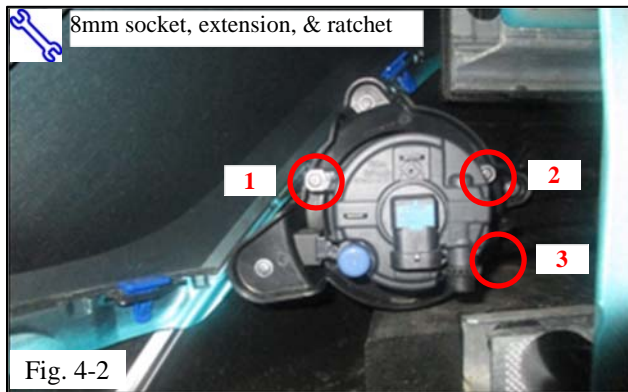

(a) Use three (3) M4.8x13mm hex-head screws to mount each fog light to each adapter (Fig. 4-2).



(b) Locate the OE harness and cut the tape (Fig. 4-3). Repeat on the opposite side.



(c) Connect the driver side adapter harness to the driver side fog light harness and then to the driver side fog light itself (Fig. 4-4).

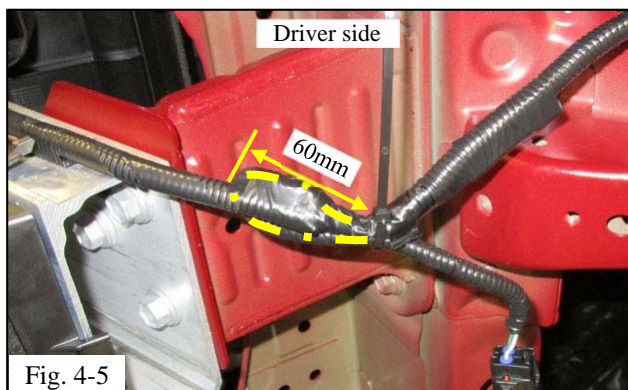

(d) Install the fog light wiring harness with a loop 60mm from the main OE bundle to ensure no interference with the front bumper members (Fig. 4-5).

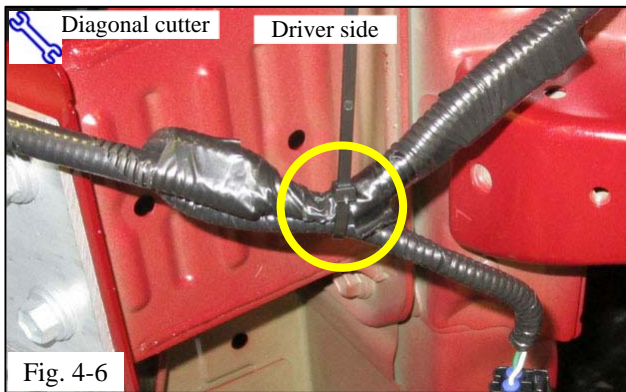

- (e) Secure the harness with one (1) wire tie and trim excess wire tie length (Fig. 4-6).

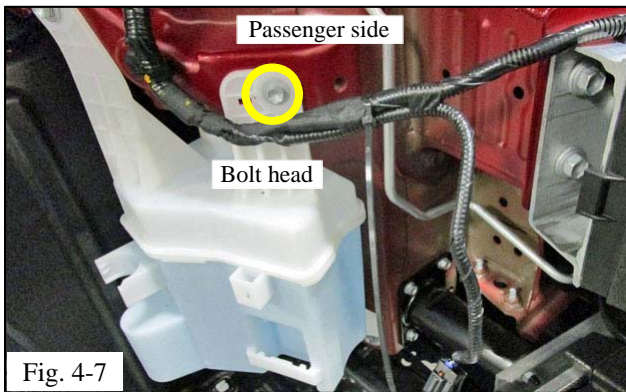

- (f) Orient the fog light wire harness beneath the OE bundle to prevent interference with the bolt head (Fig. 4-7).

**STOP CAUTION:** Be sure that the fog light wire harness is oriented under the bolt head (Fig. 4-7).



- (g) Connect the passenger side adapter harness to the passenger side fog light harness and then to the passenger side fog light (Fig. 4-8).
- (h) Verify the fog lights and harness are secure.
- (i) Reinstall the exterior panels in the reverse order they were removed.

**5. Prepare to Install the Harness.**

- (a) Remove the inner door scuff garnish (Fig. 5-1).



- (b) Remove the fastener and pull the cowl panel inboard to remove it (Fig. 5-2).



- (c) Remove the two (2) screws (Fig. 5-3).
- (d) Grasp the upper panel located below the A/C vent at the upper edge and gently pull the panel loose. Disconnect any connectors attached to it, and then remove it.





(e) Grasp the lower panel at the upper edge and gently pull the panel (Fig. 5-4), disconnecting any connectors attached to the panel, and then remove it.

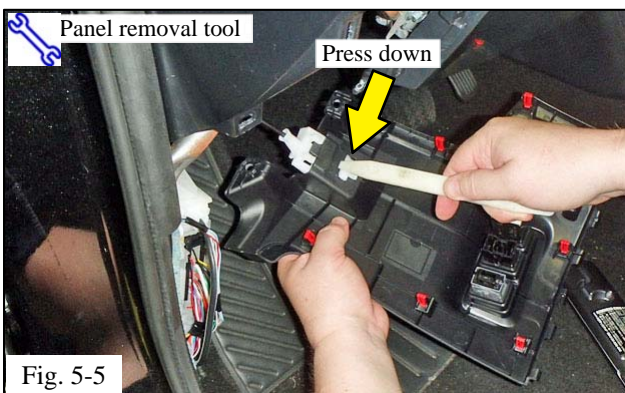

(f) Press down on the retaining clip to disconnect the hood release lever (Fig. 5-5). Disconnect the harnesses and remove the panel.



(g) Disconnect the brown plastic element blocking access (Fig. 5-6).

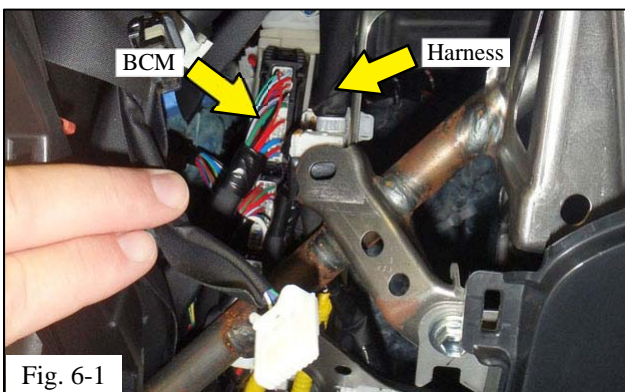

## 6. Disconnect the Body Control Module.

(a) Locate the junction block/body control module (BCM) assembly and note the harness secured in front of the BCM connectors (Fig. 6-1).



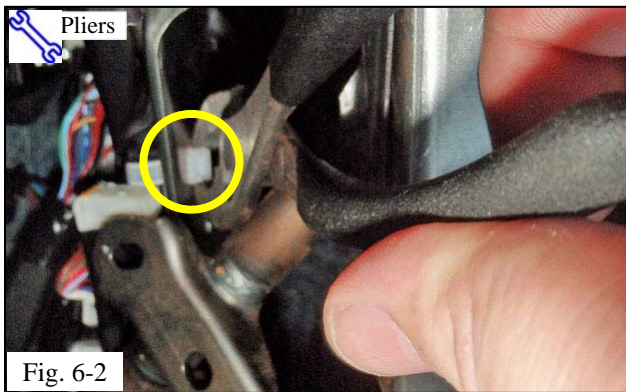

(b) Use pliers to release the stake securing the wire harness (Fig. 6-2).



(c) Pull the harness free from the bracket (Fig. 6-3).



(d) Locate the 30-pin white BCM connector (Fig. 6-4).



(e) Disconnect the 30-pin white BCM connector (Fig. 6-5).

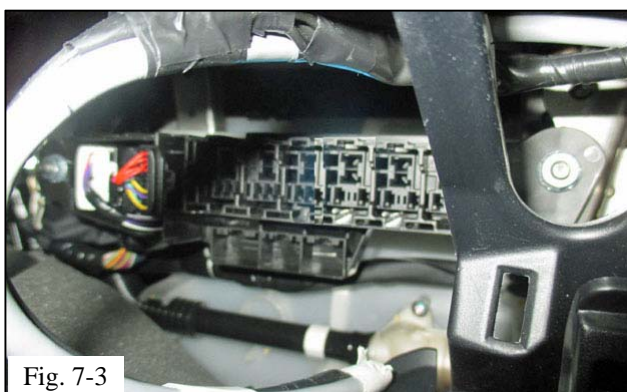

**7. Install the Relay.**

- (a) Open the glove box to access the dash panel.
- (b) Use a nylon panel tool to remove the dashboard panel in the area indicated in Fig. 7-1.

- (c) Loosen the upper center console to access the relay bank (Fig. 7-2).

- (d) Locate the relay panel behind the upper center console (Fig. 7-3).

- (e) Install the provided relay in the fourth position from the left (Fig. 7-4).
- (f) Replace the upper center console loosened in Step 7(b).
- (g) Reinstall the dash panel removed in Step 7(a).



Fig. 8-1

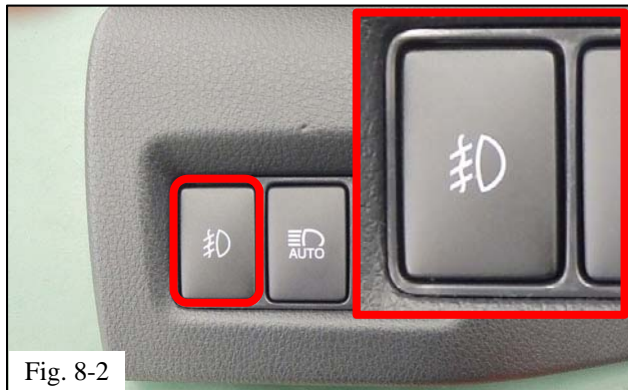

Fig. 8-2

**8. Install the Switch.**

(a) Remove the switch blank (Fig. 8-1).

(b) Install the switch. Verify the switch is oriented correctly (Fig. 8-2).

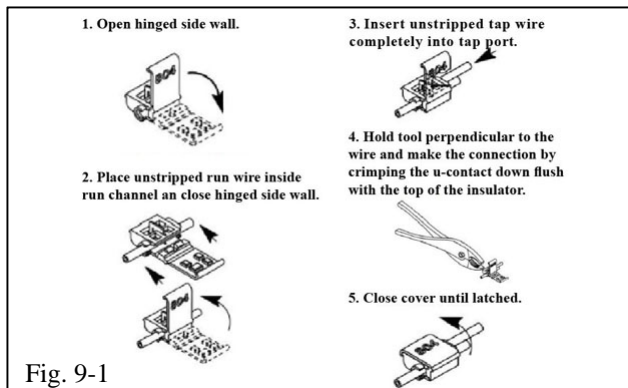

Fig. 9-1

**9. Connect the Harness.**

(a) Review the correct use of Scotchlok™ connectors (Fig. 9-1).

(b) Locate high beam harness.

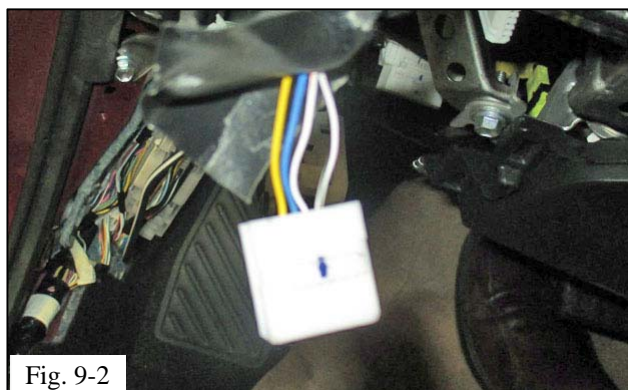
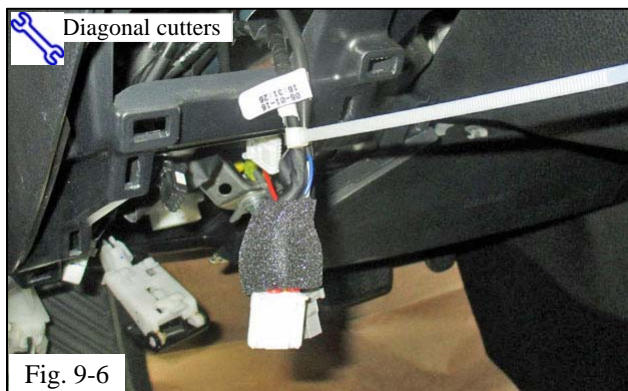
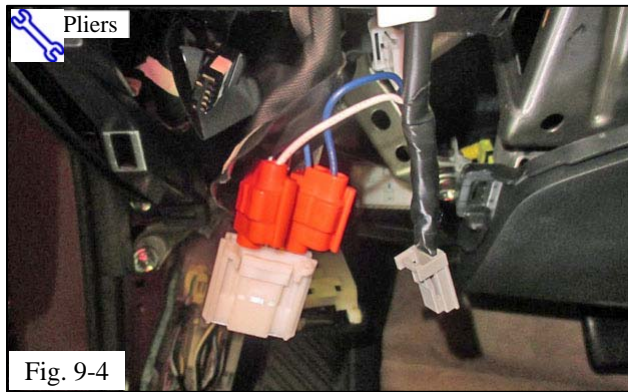
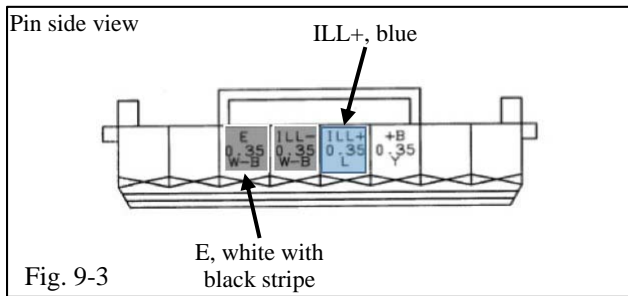

Fig. 9-2

(c) Peel the insulation on the harness back as needed to access the wires (Fig. 9-2).



(d) Locate the wires to connect to (Fig. 9-3).

(e) Use two (2) Scotchlocks to make the following connections on the high beam switch connector that was disconnected in Step 5(e) (Fig. 9-4).

(1) Connect the white wire on the switch harness to the white/black wire on the vehicle (last wire from the left).

(2) Connect the blue wire on the switch harness to the blue wire on the vehicle harness.

(f) Apply one (1) foam pad around the Scotchlocks (Fig. 9-5).

(g) Secure the pad with one (1) wire tie (Fig. 9-6). Trim the excess wire tie.



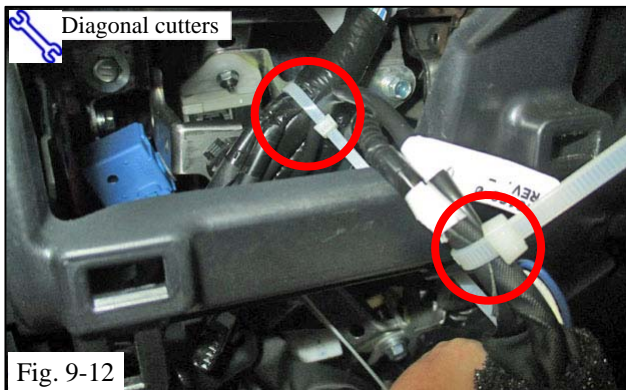
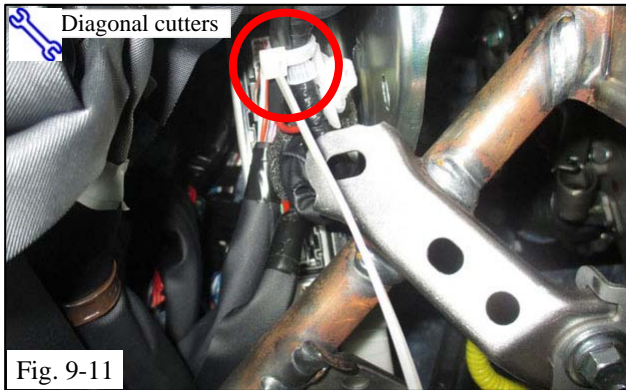

(m) Secure the harness with one (1) wire tie (Fig. 9-11). Trim the excess wire tie.

(n) Secure the harness with two (2) wire ties (Fig. 9-12). Trim the excess wire tie.

(o) Reconnect the BCM connector.

(p) Replace the brown element removed in Step 5(g).

(q) Reinstall the hood release lever.

(r) Reinstall the upper and lower panel removed in Step 5(d) and 5(e) and all of the associated connectors on these panels.

(s) Reinstall the cowl panel removed in Step 5(b).

(t) Reinstall the inner door scuff garnish removed in Step 5(a).

### 10. Reconnect the Battery.

(a) Reconnect the negative battery cable (Fig. 10-1).

 **Torque: 5.4 N•m (48 in•lbs)**

 **CAUTION:** Do not touch the positive terminal with any tool.

(b) Reinstall the weather-stripping and battery access upper cowl panel removed in Step 1(a).

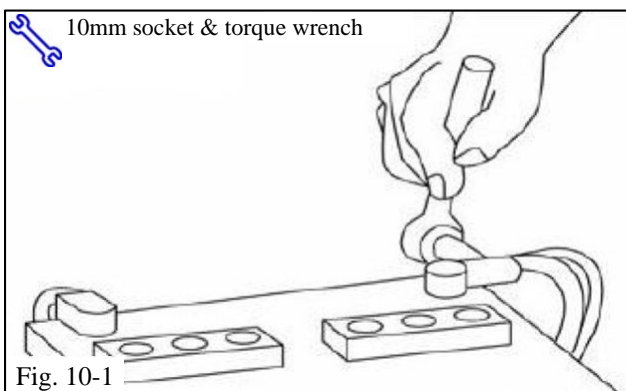

### 11. Aim the Fog Lights (DIO Only).

(a) If available, use a Hella Photometric Beam Setter (or equivalent) to align the fog light beam (Fig. 11-1).

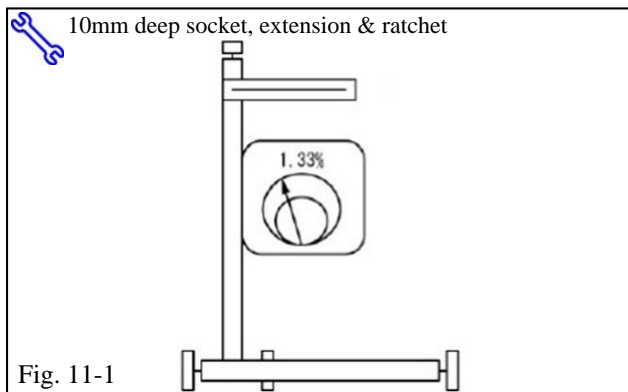

(b) If a Beam Setter is not available, use a wall to aim the lights.

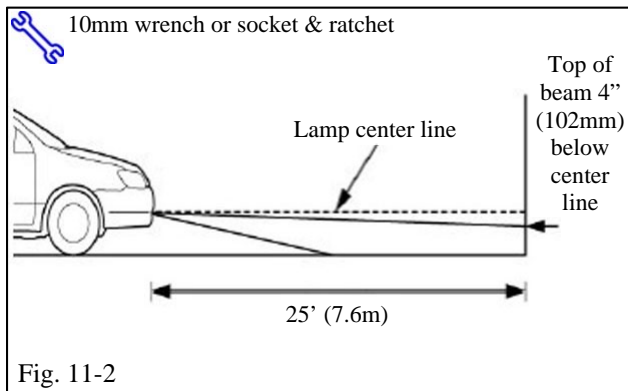

(1) Position the vehicle on a flat surface at a distance of 25 feet (7.6m) from the fog light to a wall (Fig. 11-2).

(2) Measure the distance from the center of the lamp to the ground and mark off the same height on the wall. This is the fog light centerline (Fig. 11-2).

(3) Turn on the fog lights and adjust them so that the top of the beam (high intensity portion) falls 4 inches (102 mm) below the mark on the wall (the fog light centerline) (Fig. 11-2).

(c) Use a 10mm deep socket and 8" extension to turn the adjustment screw on the fog lights.

Checklist - these points **MUST** be checked to ensure a quality installation.

<u>Check:</u>	<u>Look For:</u>
<p><u>Accessory Function Checks</u></p> <ul style="list-style-type: none"><li><input type="checkbox"/> Turn the headlights on</li><li><input type="checkbox"/> Check the fog light switch illumination</li><li><input type="checkbox"/> Turn the fog lights on</li><li><input type="checkbox"/> Switch the high beams on</li><li><input type="checkbox"/> Turn the headlights off</li><li><input type="checkbox"/> Check the fog light switch orientation</li></ul>	<ul style="list-style-type: none"><li>Headlights function as normal</li><li>Switch lights up</li><li>Fog lights turn on</li><li>High beams on/Fog lights off</li><li>Headlights and fog lights turn off</li><li>The lamp symbol faces left</li></ul>
<p><u>Vehicle Function Checks</u></p> <ul style="list-style-type: none"><li><input type="checkbox"/> Taillights/brake lights/turn signals</li><li><input type="checkbox"/> Reverse lights &amp; emergency flashers</li><li><input type="checkbox"/> Mirror/dimmer controls/fuel door switch</li><li><input type="checkbox"/> Traction control</li><li><input type="checkbox"/> Hood Release Latch</li></ul>	<ul style="list-style-type: none"><li>All function properly</li><li>Function properly</li><li>Function properly</li><li>Functions properly</li><li>Functions properly</li></ul>
<p><u>Vehicle Appearance Check</u></p> <ul style="list-style-type: none"><li><input type="checkbox"/> After accessory installation and removal of protective cover(s), perform a visual inspection.</li></ul>	<p>Ensure no damage (including scuffs and scratches) was caused during the installation process. (For PPO installations, refer to TMS Accessory Quality Shipping Standard.)</p>